

KAVSES

O-RİNG KESİTLERİNDE HATA TOLERANSLARI

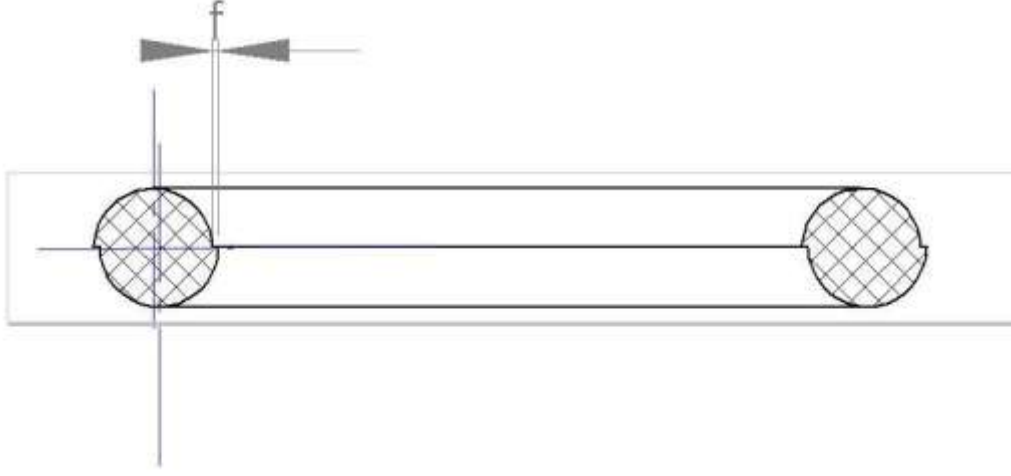

Şekil 1: Kesit kayması

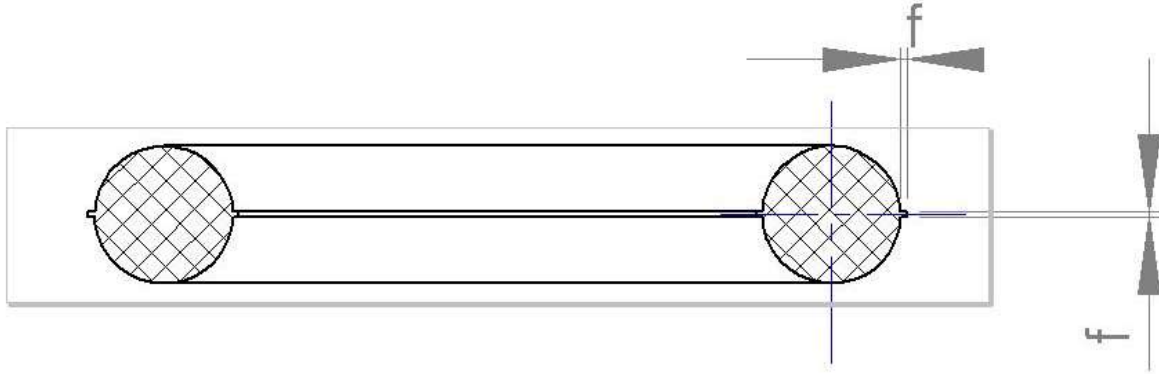

Şekil 2: Çapak

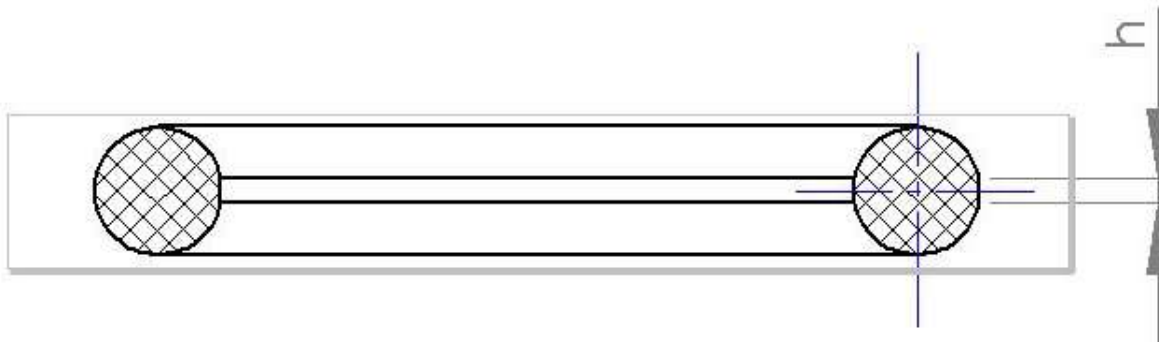

Şekil 3: Düzlük

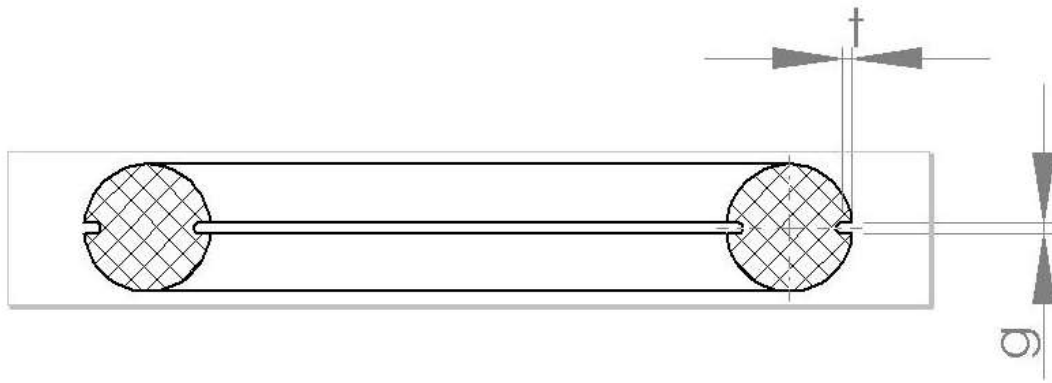

Şekil 4: Çukurluk

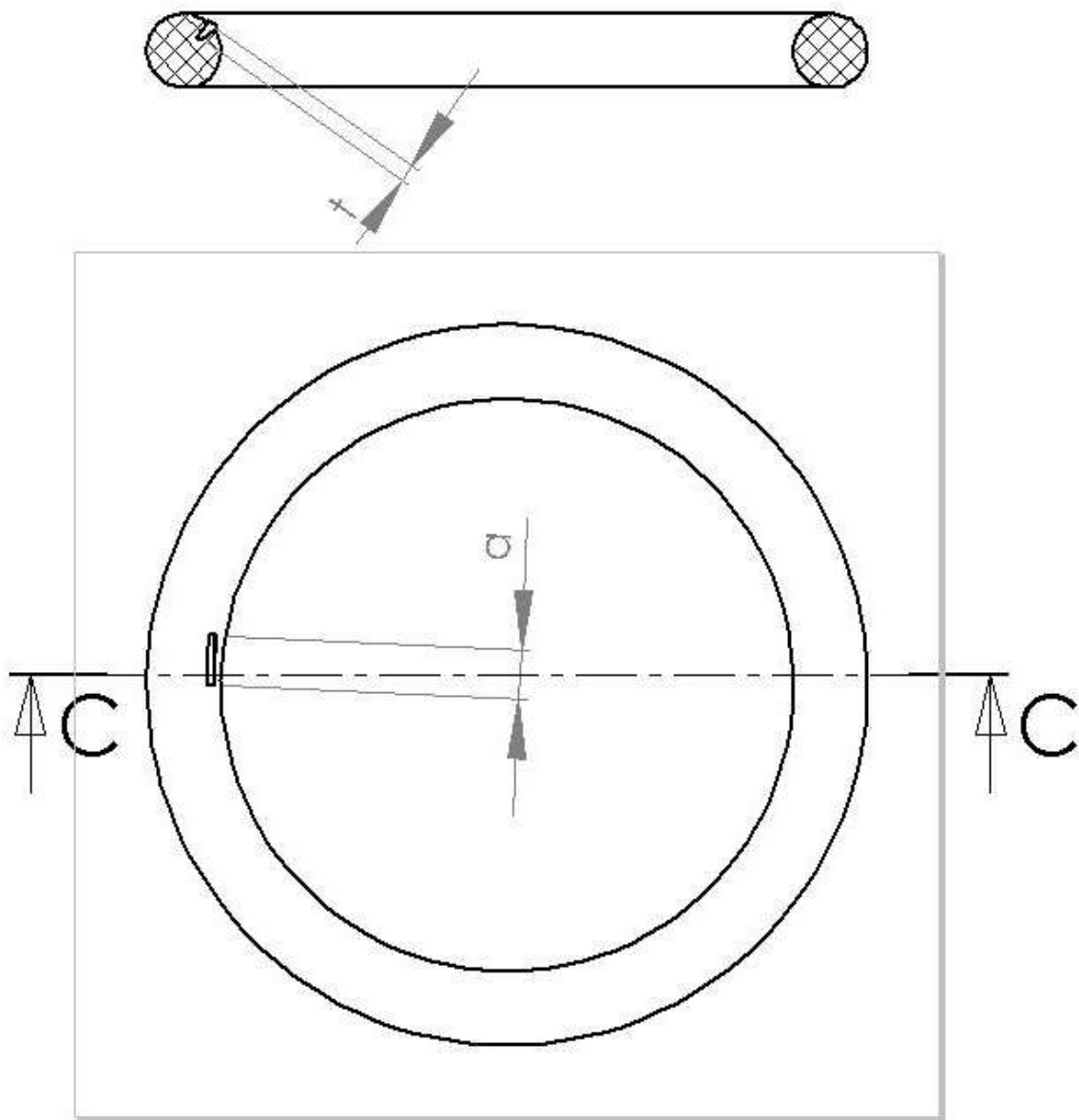

Şekil 5: Yarık

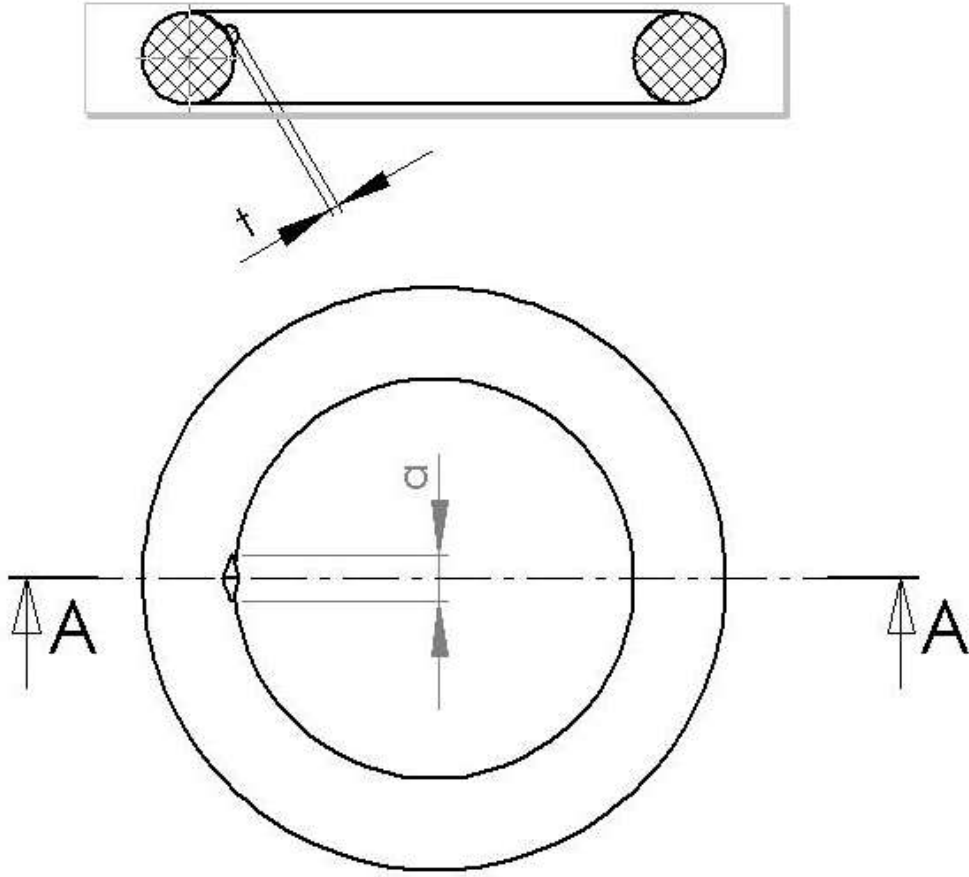

Şekil 6: Kabarcık

HATA CİNSLERİ	KESİT ÇAPLARI [mm]			
	KOD	0-3	3-7	7-15
Kesit kayması (Şekil 1)	f	0,05	0,09	0,15
Çapak (Şekil 2)	f	0,05	0,09	0,15
Düzlük (Şekil 3)	h	0,04	0,06	0,09
Çukurluk (Şekil 4)	g	0,1 x b	0,1 x b	0,1 x b
	t	0,05	0,09	0,15
Yarık ve kabartılar (Şekil 5-6)	a	0,1 x D	0,1 x D	0,1 x D
	t	0,03	0,06	0,10

Hata payları kesit çapı(b) üzerinden verilmiştir.